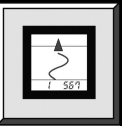

VM6800**PAPERLESS RECORDER****OUTLINE**

This is a paperless recorder that displays measured data on the LCD in real time and stores data in CompactFlash.

The type of input such as thermocouple, resistance bulb, D.C. voltage (current), etc. can be arbitrarily set to 36 channels at the maximum.

The data stored in CompactFlash can be regenerated on the screen, and the use of supplied support software allows the data to be regenerated on a PC screen.

The data recorded in ASCII format can be directly read in a spreadsheet such as Excel, which facilitates the processing on a PC. (The data recorded in binary format cannot be read in.)

FEATURES**1. Large capacity storage by CompactFlash**

Measured data is periodically stored in CompactFlash. In case of 256 MB, for example, display files for about one year and a half (display refresh cycle 30 sec) can be taken up (in case of ASCII data format, 9 channels, maximum/minimum recording).

2. Quick search and display of past data

Data stored in CompactFlash can be displayed in succession by scrolling the screen.

3. Various display capability

Depending on the object of measurement, the most suitable display format can be selected from a variety of formats including bar graph display, trend display, digital display, etc.

4. PC support software supplied as standard

Loader software that enables easy display and change of set data and data viewer software that regenerates the data stored in CompactFlash are supplied as standard.

5. 36-point recording

12 types of thermocouples, 2 types of resistance bulbs and DC voltage/current input can be recorded up to 36 points.

6. LCD extinguishing function

Automatically extinguishes the LCD if nothing is operated for certain time. You can set the time after a lapse of which the LCD is extinguished via parameter "LCD extinguishing time". The settable range is 0 to 60 minutes.

Setting at 0 minute overrides the function, whereby the LCD will never extinguish.

This function prevents the backlight life from shortening uselessly. During the extinguishment, the power consumption can be reduced.

7. Ethernet function (Option)

FTP, Web server, e-mail and MODBUS-TCP are available using 10Base-T.

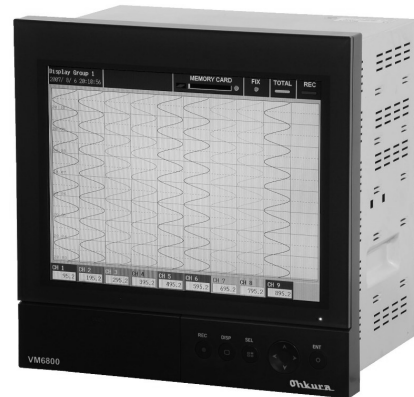
**SPECIFICATIONS****Input system****Number of input points:**

9, 18, 27 or 36 points (Can be selected at the time of purchase)

Input circuit: Input mutual isolation (See "Others" on page 4 for the withstand voltage)

Resistance bulb measured current: about. 1 mA

Measuring cycles:

9 or 18 points....100ms cycles

27 or 36 points....200ms cycles

Recording cycle: 1 second to 12 hours

Input types: Thermocouple, resistance bulb, DC voltage, and DC current (Shunt resistors are fitted in input terminals).
Note) Provide a shunt resistor (type: WPSR222B00001A) separately.

Measuring range

Input types		Reference range
Thermocouple	B	400.0 to 1760.0°C
	R	0.0 to 1760.0°C
	S	0.0 to 1760.0°C
	K	-200.0 to 1370.0°C
	E	-200.0 to 800.0°C
	J	-200.0 to 1100.0°C
	T	-200.0 to 400.0°C
	N	0.0 to 1300.0°C
	W	0.0 to 1760.0°C
	L	-200.0 to 900.0°C
	U	-200.0 to 400.0°C
PN	0.0 to 1300.0°C	
Resistance bulb	JPt100	-200.0 to 600.0°C
	Pt100	-200.0 to 600.0°C
DC voltage	50mV	0.00 to 50.00mV
	500mV	0.00 to 500.0mV
	1-5V	1.000 to 5.000V
	0-5V	0.000 to 5.000V

Note) B, R, S, K, E, J, T, N : JIS C 1602, DIN IEC 584-1
W: 5%Re-26%Re·W (Hoskins Mfg. Co. USA)
L: Fe-Cu·Ni (DIN 43710)
U: Cu-Cu·Ni (DIN 43710)
PN: Platinel
JPt100: JIS C 1604-1989 (Old JIS Pt 100)
Pt100: JIS 1604, DIN IEC 751

Selection of input types:

By key operation on the front panel. Note that the same input type (thermocouple, resistance bulb, voltage) should be set every 2 channels. Refer to "Setting method of input types" for details.

Burn-out function:

Provided as standard for thermocouple and resistance bulb inputs. If the input has been open-circuited, the recording level swings over 100%.

Thermocouple burn-out current:
approx. $0.2 \mu A$

Input filter function:

Settable for each channel (primary delay filter)
Time constants are settable in the range from 0 to 900 sec.

Scaling function:

Possible by DC voltage (current) input
Scaling range: -32767 to 32767
Decimal position: settable at any point
Unit symbol: Selectable out of 125 different units or 12 user units of up to 7 characters.

Subtraction function:

Subtraction between each channel is allowed.

Totalizing function:

The measured value of each channel can be totalized. Applicable to daily, monthly, annual or external input totalizing.

F value calculation function:

F value (extinction value of bacteria by sterilization by heating) can be calculated from the measured temperature by each channel.

Square rooter function:

Square rooter can be performed against the input value per each channel.

Computation function:

The following calculation is available with the computation function.

(1) Computation function:

Addition, subtraction, multiplication, division, absolute value, exponential, square-root extraction, LOG, LN, EXP, humidity, maximum, minimum, average, and integration.

(2) Computation input enable:

Analog input (Ch1 to 72), integration input (Ch1 to 72), DI (DI1 to 16), communication input (No.1 to 36), and constant number (No.1 to 60).

Indication system

Indicator: 12" TFT color LCD (800 x 600 dots) with backlight, no contrast adjustment.

On the LCD, certain picture elements remain lit or extinguished. On account of the nature inherent to LCD, the brightness may be non-uniform. But, such are not troubles.

Color of indication: 14 colors

Applicable language: English

Life of backlight:

50,000 hours in terms of total lighting time.

(Replace the backlight as a set of display unit. If the LCD extinguishing function is resorted to, the LCD can be used longer as much.)

Trend display:

Direction: vertical and horizontal

Number of channels: 10, 6 or 4 channels per screen group. (Input: 72 points at the maximum).

Display refreshment cycles:

select from 1 second to 12 hours

Scale display or no-display can be selected.

Bar graph display:

Number of channels: 10, 6 or 4 channels per screen group. (Input: 72 points at the maximum).

Display refreshment cycles: 1 second

Analog meter display:

Number of channels: 10, 6 or 4 channels per screen group. Display in bar graphs or in analog meters can be selected.

Display refresh cycle: 1 second

Digital display:

Number of channels: 10, 6 or 4 channels per screen group. (Input: 72 points at the maximum).

Display refreshment cycles: 1 second

Totalizing data display:

Number of channels: 10, 6 or 4 channels per screen group. (Input: 72 points at the maximum).

Display refresh cycle: 1 second

Event summary display:

Alarm summary and message summary can be displayed. The message occurrence information and message display can be switched.

Ethernet log display:

E-mail sending, FTP server log in/off and MODBUS TCP/IP communication start/stop can be displayed.

Parameter display/set:

Already-set data display and set change display screen

TAG indication:

Number of characters to be displayed:

Up to 8 characters

Up to 8 characters (Note 1) at 10 or 6 channel display.

Up to 16 characters at 4 channel display.

Note 1: Up to 7 characters only can be displayed on certain screens.

Characters to be displayed:

Alphanumerics

Tag, unit and channel No. display:

Which can be displayed depends on the particular screen. Refer to the table below.

(Keywords only are extracted.)

Screen	Channels per screen	Item			
		Tag1	Tag2	Unit	ch Np.
Trend Bar graph	4 or less	All			
	5,6	○	—	○	○
	7 or more	×	—	×	×
Analog meter	6 or less	All			
	7 or more	○	—	○	○
Instantaneous value		All			

○ : Displayed

× : 1 item only can be displayed

— : Nothing can be displayed

Historical trend display:

Displays past recording data read from compact flash, currently recording data or just recorded data. The recording chart can be scrolled or, via time designation, the control can jump to an arbitrary recording chart.

Number of screen groups:

8 groups (Up to 10 channels per 1 group can be registered.)

Keyboard

No. of Keys: 8

Function: Use to select various screens and set various parameters.

Recording function

External memory media:

Format according to FAT16 or FAT. Otherwise, reading and saving are impossible.

Recording capacity:

1GB maximum (compact flash).

Recording method:

Turning ON the REC key allows measured data to be written at fixed cycles. Recorded as a new file whenever the recording starts. The record file is made newly in every 3MB.

Data save cycles:

Linked to the display refreshment cycles on the "Real Time Trend" screen. However, they are automatically set to about 1 minute if the refreshment cycles are set to less than 1 minute.

Trend data: Measurement data sampled at measurement cycle is saved in terms of mean value, instantaneous value or maximum/ minimum value.

Event data: Saves alarm data and message data. Further saves power ON and OFF, if any, after starting recording.

Totalizing value data:

Totalizing value data at designated timing is recorded per channel. Totalized value data at designated totalized value recording cycle or the sum total is recorded in the totalizing file. You can choose which type you want to record.

For each channel, it can be selected as totalizing action from Analog input totalization, Digital input count or period of Digital input ON, and it can be selected as totalizing period type from Dairy, Weekly, Monthly, Annual, Periodic, Dairy (time set) or External input signal.

Even if a power failure occurs during totalization and then the power is restored, the totalization restarts from the value before power failure.

Configuration data:

Configuration data can be saved. And this data can also download to recorder.

Storage capacity :

Approximately 1.5 years when the display refresh cycle is 30 seconds (in case of 36-channel recording in ASCII data format, and 1GB compact flash used). Refer to Table 1.

Residual capacity of memory:

Indicates how much of the memory card has been used on the screen. If the residual capacity is none, the recording stops.

Compact flash:

Manufactured by SanDisk
URL: <http://www.sandisk.com>
Type: SDCFB-256-J60 (256MB)
Available at any PC shops

Data format: Either of ASCII or binary format can be selected. (Switching cannot be made while the recording is in progress. In the case of ASCII format, the data can be directly read on Excel, etc. The data recorded in binary format cannot be read directly.)

Approximately 166 bytes per sampling for maximum/minimum recording of 9-channel input in ASCII format, or approximately 40 bytes for maximum/minimum recording of 9-channel input in binary format.

Alarm function

No. of settings:

Up to 4 alarms for each channel are settable.

Type of alarm:

High/Low limits
Indication: Status (alarm types) is displayed on digital display unit when an alarm occurs. Historical display on alarm summary (Alarm start/cancel time and alarm types)

Hysteresis: Set within the recording range of 0 to 100%

Acts on high or low limit alarm, and does not affect the battery alarm nor memory full alarm.

Relay output: Number of points; 20 (option: Up to 2 cards with relay output can be mounted.)

Transistor output (open collector output):

16 points (option)

Alarm latch function:

Holds alarm indication and alarm output even after measurement value has left the alarm range.

ON/OFF operation is performed according to key setting.

Power supply

Rated power voltage:

100 to 240V AC

Range of operating voltage:

90 to 264V AC

Supply frequency:

50/60Hz $\pm 2\%$ (both employable)

Power consumption

Power voltage	consumption
100V AC	About 65VA
240V AC	About 80VA

Structure

Mounting method:

Panel-mounted (vertical panel)

Thickness of panel:

2 to 26 mm

Materials: Stainless steel for case, PC-ABS for bezel

Color: Silver for case, Munsell N2.0 (black) for bezel

External dimensions:

300 (W) \times 300 (H) \times 220.5 (D) mm

Mass: About 4.7 kg (9-point input, without option)

About 6.4 kg (full option)

External terminal board:

Input terminal: M3 screw terminal

Power terminal: M4 screw terminal

Operating condition

Ambient temperature:

Without Ethernet function: 0 to 50°C^{*1}

With Ethernet function: 0 to 40°C^{*2}

Ambient humidity:

20 to 80%RH

Vibration: 10 to 60Hz 0.2m/s² or less

Shock: None

Magnetic field: 400 A/m max.

Signal source resistance:

Thermocouple input 1k Ω max.

Resistance bulb input 10 Ω /wire max.
(resistance of each wire of 3-wire system should be balanced).

Voltage input 0.1% max. of input resistance

Mounting posture:

Forward tilt 0, backward tilt within 30, horizontal 0

Warm-up time: One hour or more after power ON

*1: In case of the 12th digit of ordering code is "Y".

*2: In case of the 12th digit of ordering code is "E".

Reference standard

Accuracy/resolution:

Measuring conditions (23 \pm 2°C, 65 \pm 10% RH, power voltage, frequency fluctuation within $\pm 1\%$, no external noise, warm-up time of 1 hour or more, vertical mounting, standard values of signal source resistance and wiring resistance... within 1%)

Input types		Digital indication accuracy	Note 1	Digital indication resolution
Thermo-couple	B	$\pm(0.15\%+1 \text{ digit})$ $\pm(0.3\%+1 \text{ digit})$ for the range shown below Thermocouple B: 400 to 600°C Thermocouples R and S: 0 to 300°C Thermocouples K, E, J, T, L and U: -200 to -100°C		0.1°C
	R			
	S			
	K			
	E			
	J			
	T			
	N			
	W			
	L			
U				
PN				
Resistance bulb	JPt100 Pt100	$\pm(0.15\%+1 \text{ digit})$		0.1°C
DC voltage	50mV	$\pm(0.15\%+1 \text{ digit})$		10 μ V
	500mV			100 μ V
	5V			1mV

Note 1) Digital indication accuracy is a percentage (%) with respect to input range of 1 page.

Note 2) No error of reference contact compensation of thermocouple is included.

Error of reference contact compensation:

K, E, J, T, N, L, U, PN: $\pm 0.5^\circ\text{C}$

R, S, B, W: $\pm 1.0^\circ\text{C}$

(when measured at 0°C or more)

Max. input voltage:

Thermocouple, resistance bulb,
DC voltage: $\pm 10\text{V}$ DC (continuous)

Input impedance:

Thermocouple, DC voltage: About 1M Ω

Others

Clock: With calendar function (Christian era)
Accuracy: ± 50 ppm or less (monthly error: about 2 minutes)
However, time error at power ON/OFF is not included.

Memory backup: Parameters are saved to the internal non-volatile flash memory.
The clock is backed up with built-in lithium battery.
Trend data is not backed up.

Insulation resistance:

100 M Ω (when measured between each terminal and ground by using a 500V DC megger)

Withstand voltage:

Input terminal—input terminal:
500 V AC, 1 min
Power terminal—ground:
2000V AC, 1 min
Input terminal—ground: 500V AC, 1 min
Alarm terminal (contact output)—ground:
2000 V AC, 1 min
Alarm terminal (contact output)—alarm terminal (contact output):
750 V AC, 1 min
Communication terminal—ground:
500 V AC, 1 min
Alarm terminal (open collector)—ground:
500 V AC, 1 min
Power terminal – input terminal:
500 V AC, 1 min

Effect on operation

Effect of power supply fluctuation conditions:

For the fluctuation in the range from 90 to 264V AC (frequency: 50/60Hz)
Reading change: $\pm(0.2\%+1 \text{ digit})$ or lower.
For the fluctuation in the range from 47 to 63Hz (power voltage: 100V AC)
Reading change: $\pm(0.2\%+1 \text{ digit})$ or lower.

Effect of input signal resistance:

Thermocouple input: $50 \mu\text{V} \pm 1 \text{ digit per } 100\Omega$
DC voltage: Fluctuation for resistance value equivalent to 0.1% of the input resistance: $\pm(0.2\%+1 \text{ digit})$ or lower.
Resistance bulb (for wiring resistance of 10Ω for 1 line (the same for 3 lines))
Reading change: $\pm(0.2\%+1 \text{ digit})$ or lower.

Effect of ambient temperature:

Reading change: $\pm(0.3\%+1 \text{ digit})/10^\circ\text{C}$ or lower.

Effect of Mounting position:

For the backward 30° slant
Reading change: $\pm(0.2\%+1 \text{ digit})$ or lower.

Effect of vibration:

When sine wave of 10 to 60Hz with the acceleration of 0.2m/s^2 is applied in each direction for 2 hours.
Reading change: $\pm(0.2\%+1 \text{ digit})$ or lower.

Safety and EMC standard

Safety standard: Based on IEC61010-1

EMC standard: Based on EN61326

Transportation/storage conditions

Temperature: -10 to $+60^\circ\text{C}$

Humidity: 5 to 90%RH

Vibration: 10 to 60Hz, 2.45 m/s^2 or lower

Shock: 294m/s^2 or lower (packed state)

Additional function (option)

■ Alarm relay output (11th digit of code symbols: "1", "2", "4" or "5")

Up to 2 cards with 10-point relay output can be mounted. (Maximum 20 points)

Terminal structure: M3 screw terminal

Alarm relay output:

1a contact output (10 points/card),
Individual channel or common output (OR output) allowed.
Rating: Contact capacity 240V AC/3A,
30V DC/3A (Resistive load).

■ Alarm open collector output (11 digit of code symbols is "3", "4" or "5")

Card having 16 alarm points (open collector output) can be mounted.

Terminal structure: M3 screw terminal

Alarm output:

Open-collector transistor output (16 points)
Rating: 30V DC/0.1A (resistance load)

■ DI input (7 digits of code symbol is "1")

Card having 16 DI input can be mounted.

Terminal structure: M3 screw terminal

DI input: No-voltage contact input (16 points)
Contact input allows following controls.

- (1) Recording start/stop
- (2) Message set
- (3) F value calculation reset
- (4) Totalizing start/stop
- (5) Totalized value reset
- (6) LCD (backlight) lighting
- (7) E-mail sending

Input pulse width:

ON pulse width: 400msec min.
OFF pulse width: 400msec min.

Ethernet (Option)

The following can be performed through the Ethernet function.

■ HTTP server (Internet Explorer 6 is available) ^{Note1}

Measurement display:

Digitally displays the measurement of each channel of the recorder and alarm occurrence status.

Event summary display:

Displays event summary including alarm ON /OFF and issuance of messages.

Main unit information display:

Displays memory use conditions and information on the main unit such as the battery end warning.

Integrated value display:

Digitally displays the integrated value of each channel of the recorder.

■ FTP server (Internet Explorer 6 available.) ^{Note1}

File download:

Record files stored in compact flash(CF) can be downloaded from the browser.

File delete: Record files stored in CF can be deleted from the browser.

Access authentication:

Authenticates access authority to FTP server.

■ SMTP (e-mail client)

Transmits e-mails to specified address under the following conditions.

- (1) When an alarm turns ON or OFF
- (2) When DI is set to ON or OFF
- (3) When an error occurs to the main unit (such as low battery or no memory space)
- (4) At specified intervals

■ MODBUS TCP/IP

Data read: Settings can be read through MODBUS TCP/IP communication.

Data write: Settings can be written through MODBUS TCP/IP communication.

Note1: Neither Netscape nor Mozilla Firefox are available.

Support software

The following software is provided as standard.

- Applicable PC: PC/AT-compatible machine
- Operation on PC98-series machines by NEC is not guaranteed.
- Operation on self-made or shop-brand PCs is not guaranteed.

■ Loader software for PC

Major function:

Performs various parameter setting/change of the main unit

O/S: Windows 2000/XP (Windows Vista is not supported.)

Required memory: 64MB or larger

Disk drive: Windows 2000/XP-capable CD-ROM

Hard disk capacity:

Free capacity of 30MB or larger required

Printer: Windows 2000/XP-capable printer and printer driver

Note) PC loader communication cable (type WPSR222B00-0005A) is separately required.

■ Data viewer software

Major function: Regenerates the past trend record on the PC from the data in the compact flash. event display functions.

Data can be changed to CSV file.

O/S: Windows 2000/XP (Windows Vista is not supported.)

Required memory: 64MB or larger

Disk drive: Windows 2000/XP-capable CD-ROM drive

Hard disk drive:

Free capacity of 30MB or larger required

Printer: Windows 2000/XP-capable printer and printer driver

Standard functions

Function	Description
Record range voluntary setting	Recording range can be set by channel.
Input type setting	Input type can be set by channel. (Key operation on the front face) Set the same input type for every 2 channels.
Skip function	Skips arbitrary channel display/recording.
Trend display	Time display: Time is displayed at the top of the trend display screen. Alarm display: On occurrence of an alarm and the restoration, alarm is displayed in the alarm display field. The compact flash usage is displayed with a bargraph at the top.
TAG name display	By channel, Maximum of 8 characters.
Screen name display	Displays the screen name (maximum of 16 characters).
Unit creation	Industrial units can be arbitrarily created, Maximum of 7 digits, 12 types.
Scaling function	Arbitrary scaling is allowed in the case of DC voltage input. Decimal point position can also be arbitrarily set in the range from -32767 to 32767.
PV shift	Shift the zero point and slant of the reading.
Input filter	Prevents sudden fluctuation of input for each channel (primary delay filter). Time constant: 0 to 900 seconds.
Burnout function	Displays the break of thermocouple/resistance bulb input by scaling out to 100% side.
Historical trend display	Regenerates and displays the data stored in the compact flash by scrolling the screen. Displays data of a designated time.

Table 1. Recording capacity

The recording can be made for the period of time listed in the tables shown below under the following conditions.

- 9 input points
- Recording data format: ASCII
- Recording type: Maximum/minimum recording
- No alarm, nor message, nor other events.

CompactFlash size	256MB			
Display upgrade cycle	1 sec	10 sec	30 sec	1 min
Recordable capacity(about)	17 days	179 days	1.4 years	2.9 years

CompactFlash size	512MB			
Display upgrade cycle	1 sec	10 sec	30 sec	1 min
Recordable capacity(about)	35 days	358 days	2.9 years	5.8 years

CompactFlash size	1GB		
Display upgrade cycle	1 sec	10 sec	30 sec
Recordable capacity (about)	71 days	1.9 years	5.8 years

- When the number of input points goes on increasing, the period becomes as follows.
 - 18 input points; The period is approximately one half of those listed in the table.
 - 27 input points; The period is approximately one-third of those listed in the table.
 - 36 input points; The period is approximately one-fourth of those listed in the table.
- In binary format, the period is approximately 4 times as long as those listed in the table.
- For recording type of mean or instantaneous value, the number of days is approximately 2 times as long.

When compact flash is not used, up to 6M bytes of the recording data and the event data can be stored in the main unit. (In case of 32-channel in Max./Min. recording, approximately 400,000 data can be stored. For 11 hours at the display refresh cycle of 1 second. The number of the save data varies depending on the number of the event data.

MODEL CODE NUMBER

1 2 3 4 5 6 7 8 9 10 11 12 13 14 15
V M 6 8 **A** **1** **A 0 0**

Digit	specifications	code
5,6	<Number of input points>	
	9	09
	18	18
	27	27
	36	36
7	<Mounting>	
	Panel mounting	A
8	<Language(Instruction manual)>	
	Japanese	0
	English	1
9	<Software>	
	Type 1	1
10	<Alarm output/DI input>	
	Without	0
	With(16points)	1
11	<Alarm output>	
	Without	0
	10 relays	1
	20 relays	2
	16 transistors (Open collector)	3
	10 relays and 16 transistors	4
12	<Ethernet function>	
	Without	0
	With	1

STANDARD ACCESSORY

Item	Quantity
Recorder	1
Panel mounting bracket	1
CD-ROM PC support software instruction manual	1
Noise filter for the power supply	1

OPTIONAL ITEMS

Item	Code	Specification
Shunt resistor for DC current input	WPSR222B000001A	10Ω ± 0.1%
PC loader communication cable	WPSR222B000005A	Length 3m with Connector USB-A/USB miniB terminal *
PC card adapter	SDAD-38-J60	For compact flash
Compact flash	WMSU0595A05	1GB
	WMSU0595A06	1GB

* Shape of this cable is shown below
 USB(A) male - USB(Mini-B) male

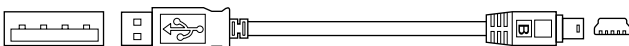

DIMENSIONS (Unit : mm)

PANEL MOUNTING

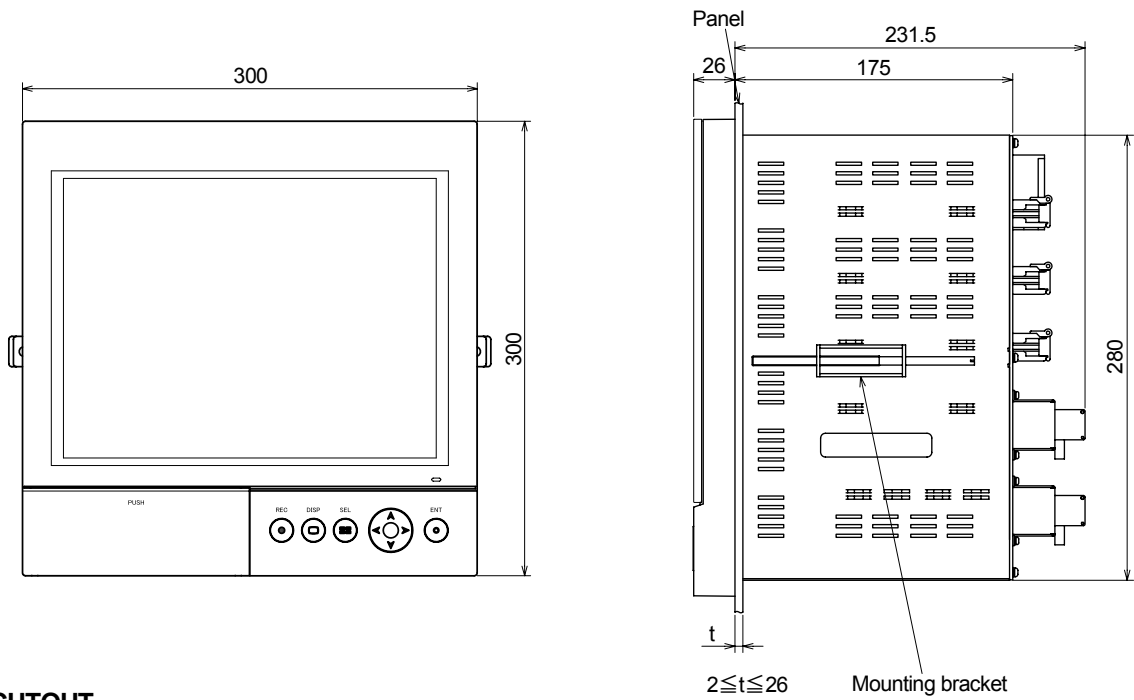
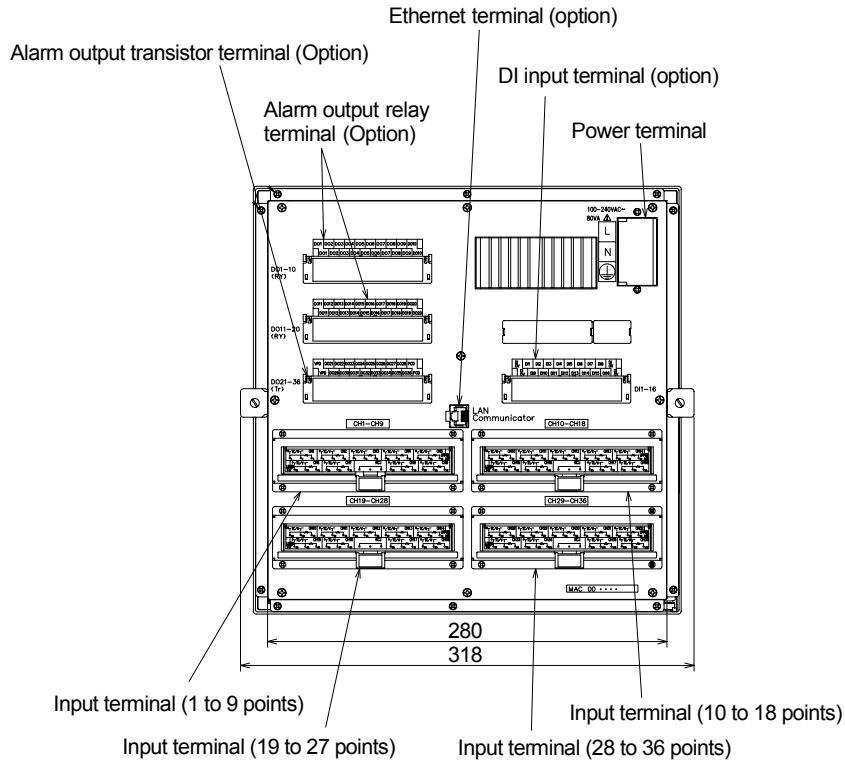

PANEL CUTOUT

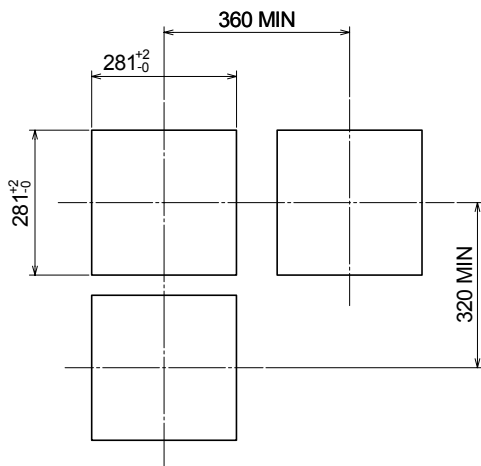

EXTERNAL CONNECTION DIAGRAMS (M3 screw)

PANEL MOUNTING

Alarm output relay terminal

M3 screw

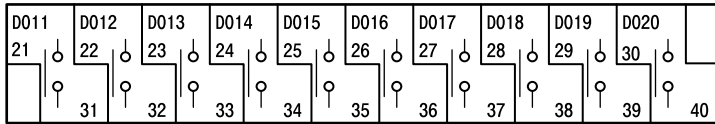
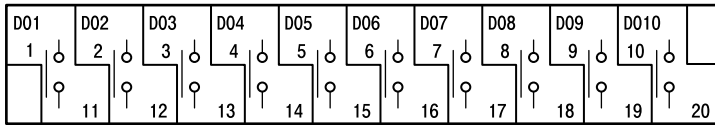

Power terminal

M4 screw

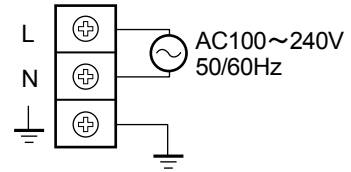

Alarm output transistor terminal

M3 screw

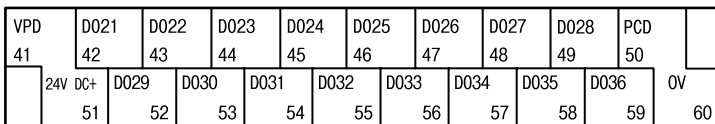

DI input terminal

M3 screw

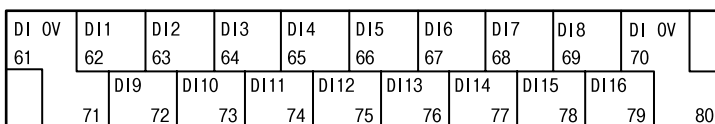

Input terminal

M3 screw

Number of input points = 1 to 9 points

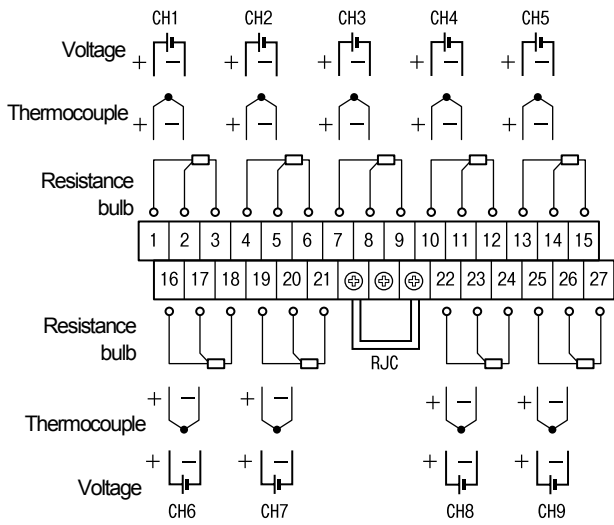

Number of input points = 10 to 18 points

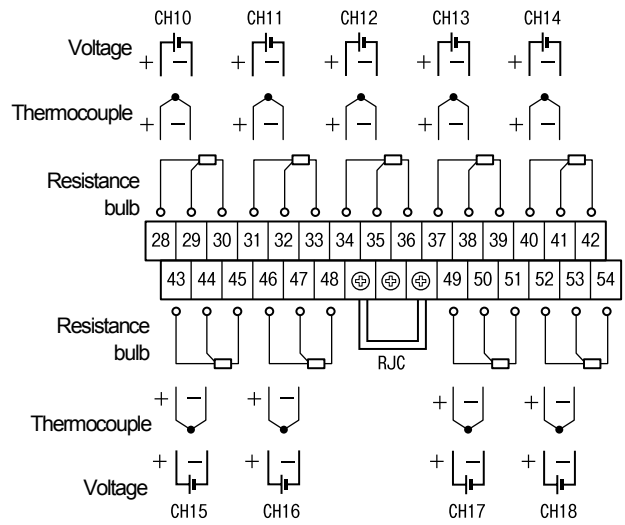

Number of input points = 19 to 27 points

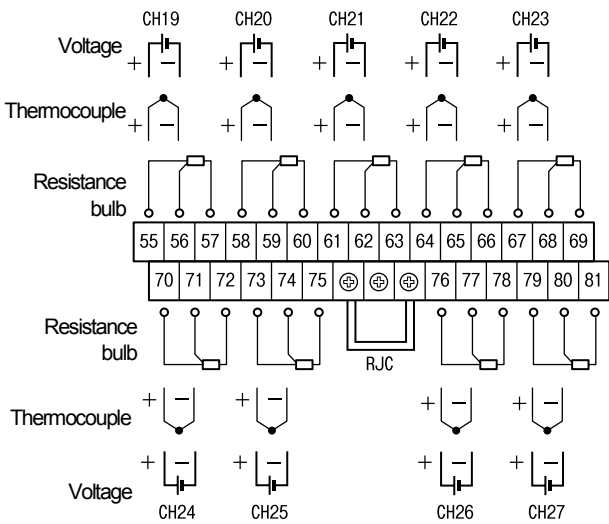

Number of input points = 28 to 36 points

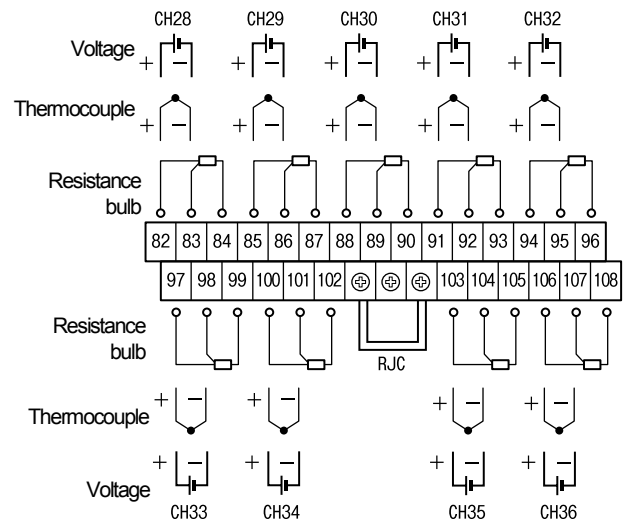

SELECTING INPUT TYPE

The input type is the same every 2 channels.

The input type of channel 2, 4, 6, 8, 11, 13, 15, 17, 20, 22, 24, 26, 29, 31, 33 and 35 can only be set in the same category of previous channel.

Note, however, that input type can be arbitrarily selected only for channels 9, 18, 27 and 36 irrespective of the type allocated to other channels.

The following input types are available.

Input type	Details
Thermocouple, 50mV	K, E, J, T, R, S, B, N, W, L, U, and PN thermocouples, 50mV
Resistance bulb	Pt100, JPt100
500mV	500mV
5V	1 to 5V, 0 to 5V

EXAMPLE OF CHANNEL INPUT TYPE SELECTION (FOR 18 POINTS INPUT)

	Input type	Input type	Description
Channel 1	K thermocouple	Thermocouple, 50mV	The type of thermocouple can be arbitrarily selected for each channel.
Channel 2	T thermocouple		
Channel 3	1-5V	5V	
Channel 4	0-5V		
Channel 5	Pt100	Resistance bulb	The type of resistance bulb can be arbitrarily selected for each channel.
Channel 6	JPt100		
Channel 7	500mV	500mV	
Channel 8	500mV		
Channel 9	J thermocouple	Thermocouple, 50mV	Input type can be arbitrarily selected for channel 9.
Channel 10	K thermocouple	Thermocouple, 50mV	The input type of the thermocouple and 50mV is the same.
Channel 11	50mV		
Channel 12	Skip	5V	Skip and other channel can arbitrarily be selected irrespective of the input type.
Channel 13	1-5V		
Channel 14	Pt100	Resistance bulb	
Channel 15	Skip		
Channel 16	Other channels	500mV	
Channel 17	500mV		
Channel 18	50mV	Thermocouple, 50mV	Input type can be arbitrarily selected for channel 18.

Note 1) Windows2000/XP, Excel, and Internet Explorer are the trademarks or registered trademarks of Microsoft Corporation in the U.S.

Note 2) CompactFlash is the trademark or registered trademark of Sandisk Corporation.

Note 3) Modbus is the trademark or registered trademark of AEG Schneider Automation International.

Note 4) The PC98 Series are the trademark or registered trademark of NEC Corporation.

Note 5) Netscape is the trademark or registered trademark of Netscape Communications Corp.

Note 6) Firefox is the trade mark of Mozilla Corporation.

CAUTION

Do not install this device before consulting instruction manual

Specifications are subject to change without notice.

For further information, a quotation or a demonstration please contact to:

Ohkura

OHKURA ELECTRIC CO., LTD.

Head Office / Factory

Saitama, JAPAN

Sales Offices

Tokyo, Osaka, Nagoya, Kyushu

URL

<http://www.ohkura.co.jp/>

e-mail (in English)

contact_e@ohkura.co.jp