

Equilibratrici
per dischi freno

Brake discs
balancing machines



CEMB

BALANCING MACHINES



Equilibratrici per dischi freno

Brake discs balancing machines

Le equilibratrici Cemb per dischi freno sono completamente automatiche ed in grado di eseguire il rilievo dello squilibrio, il posizionamento del rotante per la compensazione, il bloccaggio dello stesso su una tavola girevole, l'asportazione, mediante fresatura, della quantità di materiale sufficiente per l'equilibratura e il controllo finale del rotante per assicurarsi che la tolleranza impostata sia stata raggiunta.

The fully automatic Cemb brake discs balancing machines are capable to carry out the measuring of unbalance, the indexing of component for the compensation, the clamping of the component on a rotary table, the milling of material by a quantity of material enough to obtain the balancing and the final checking of the component to ensure that the final tolerances has been reached.

VPUBK30/TO:

Equilibratrice per dischi freno auto
Portata massima 30 kg

Car brake discs balancing machine
Max disc weight 30 kg



VPUBK40/TO:

Equilibratrice per dischi freno camion
Portata massima 40 kg

Truck brake discs balancing machine
Max disc weight 40 kg



DATI TECNICI

TECHNICAL SPECIFICATION

Model		VPUBK30 CAR	VPUBK40 TRUCK
Min/Max spessore disco <i>Min/Max disc thickness</i>	mm	10/40	20/40
Min/Max diametro <i>Min/Max diameter</i>	mm	220/400	260/600
Diametro fresa <i>Milling cutter diameter</i>	mm	125	160
Velocità di rotazione mandrino fresa <i>Mill spindle rotation speed</i>	rpm	500	400
Potenza motore fresa <i>Mill motor power</i>	kW	5,5	7,5
Attacco fresa <i>Milling cutter fitting</i>	type	ISO 40	ISO 50

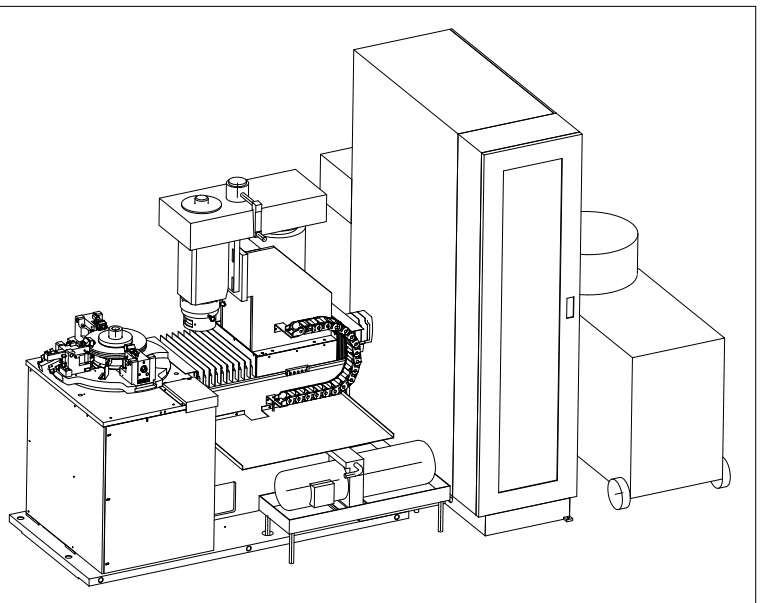

Linea di equilibratura automatica monostazione con caricatore due bracci e rulliere
Single station automatic balancing system with two arms loader and conveyors

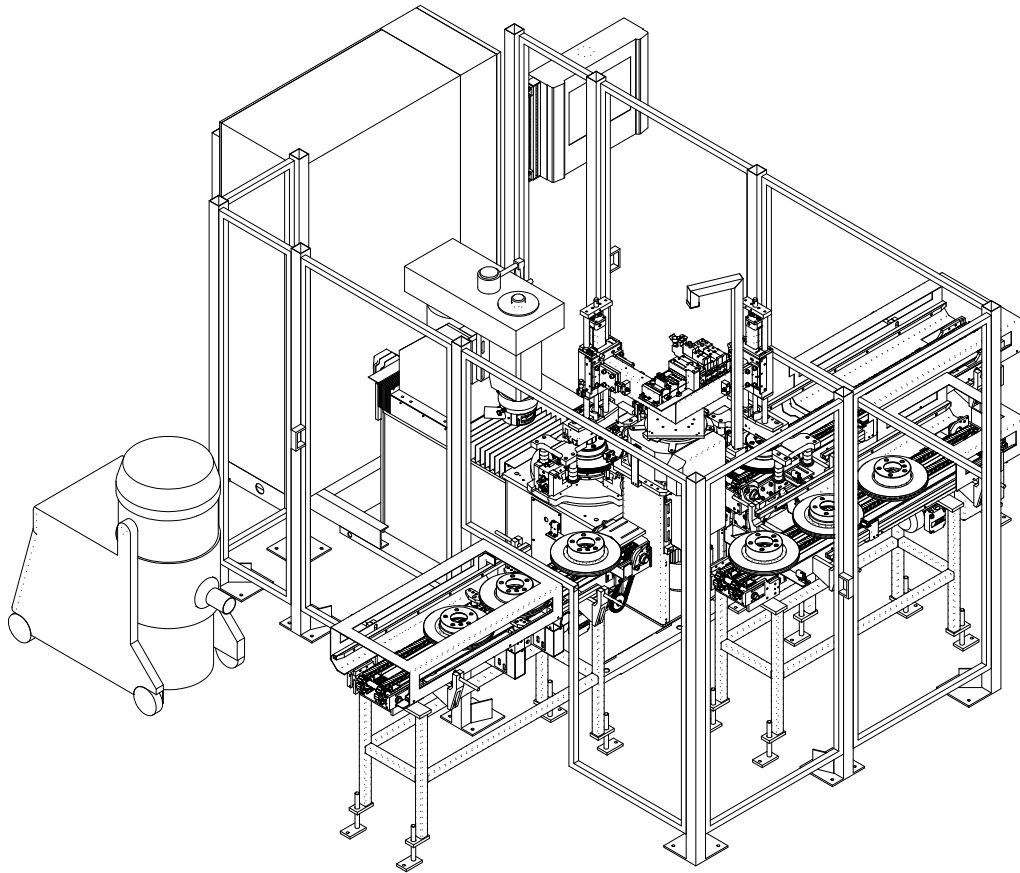

PRESTAZIONI
PERFORMANCES

- Equilibratrice a supporti rigidi. Sensori piezo-elettrici adatti per ambienti industriali.
- Pannello comandi di misura digitale tipo touch screen.
- Ciclo completamente automatico, carico/scarico con Robot e conveyors.
- Unità di correzione con asse controllato orizzontale (asse verticale opzionale).
- Alimentazione pezzi a lotti (random opzionale).
- Possibilità di compensare squilibri sistematici.
- Possibilità di marcatura pezzi (opzionale).

- Hard bearing balancing machine with piezo electric sensor suitable to work in industrial environment.
- Touch screen digital control panel.
- Fully automatic cycle with manual loading/unloading by a Robot and conveyors.
- Milling unit with horizontal and vertical (option) controlled movements.
- Batch or random (optional) operational mode.
- Possibility of systematic unbalance compensation.
- Possibility of marking pieces (optional).

DIMENSIONI DI INGOMBRO
LAYOUT DIMENSIONS

- A _ Loader
- B _ Measuring unit
- C _ Milling unit
- D _ Control unit
- E _ Touch screen panel B11

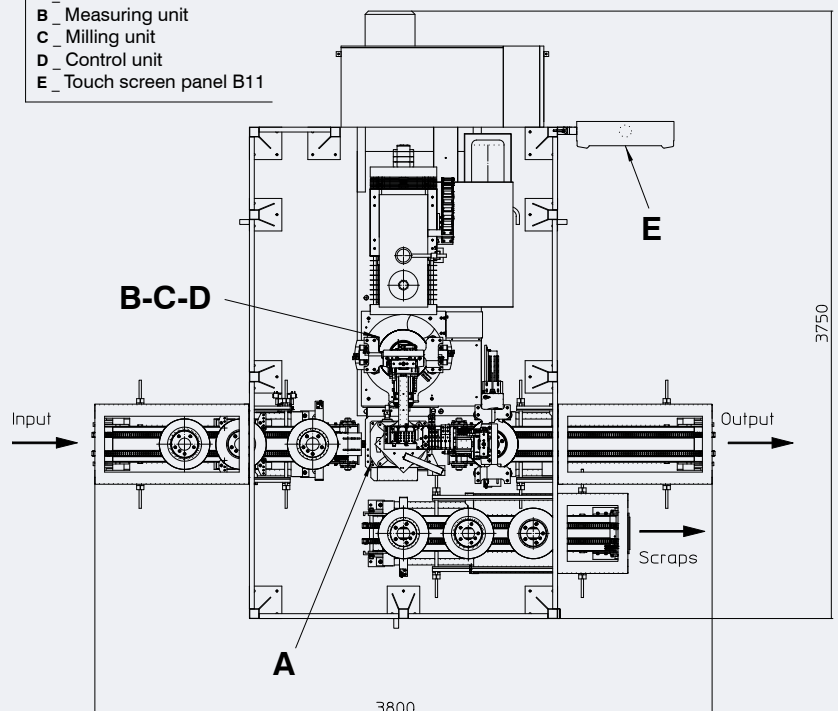

Linea di equilibratura automatica a tre stazioni con caricatore quattro bracci e rulliere
Three station automatic balancing system with four arms loader and conveyors



PRESTAZIONI
PERFORMANCES

- Tempo di ciclo ridotto e controllo squilibrio al 100%.
- Riconoscimento pezzo tramite lettura automatica dell'altezza e del diametro del disco.
- Correzione dello squilibrio mediante fresatura su stazione dedicata.
- Smistamento dei pezzi a fine ciclo sulla rulliera in uscita, con deviatore per pezzi buono/scarto.
- Possibilità di marcatura pezzi (opzionale)

- Reduced cycle time and 100% control of the residual unbalance.
- Disc recognizing by the reading of its height and diameter.
- Unbalance correction by milling operation on a specific station.
- Selection of the discs at the end of the cycle on the output conveyors by a switch for good or rejected parts.
- Possibility of marking pieces (optional).

DIMENSIONI DI INGOMBRO
LAYOUT DIMENSIONS

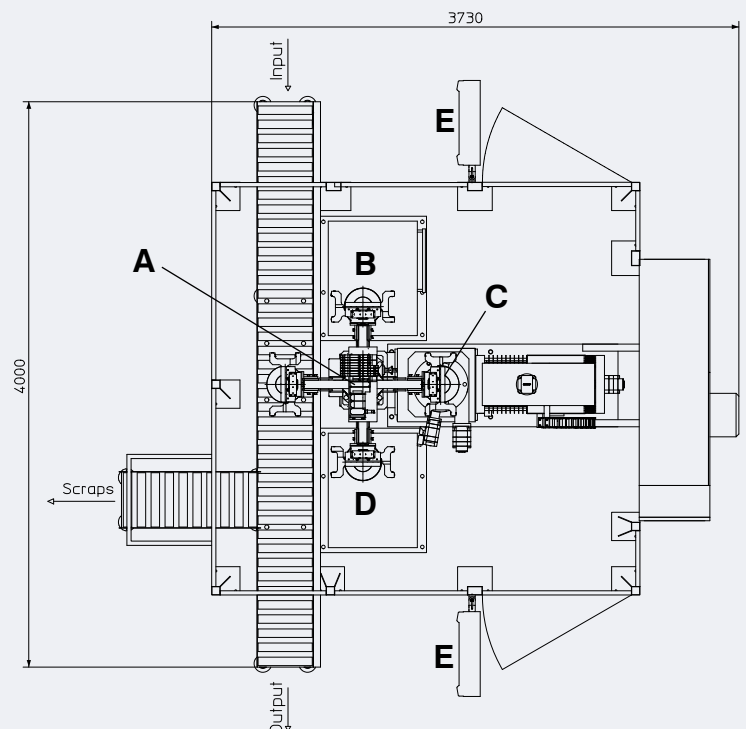



Applicazioni speciali Special applications:

Dettaglio di mano di presa caricatore e staffaggi
Detail of the loader picking gripper and clampings



Marcatore a micropunti su trasportatore in uscita
Micropoints marker placed on the output conveyor



Equilibratrice dischi freno camion
Truck discs balancing machine



Equilibratrice a due piani di correzione per dischi freno elettrici
Electrical brake disc two planes balancing machines



Equilibratura di tamburi auto
Car drum balancing



Equilibratura di tamburi camion
Truck drum balancing



All the data and features mentioned in this catalogue are purely for information and do not constitute any commitment on the part of our company, which reserves the right to make any and all alterations it may consider suitable without notice.



CEMB

BALANCING MACHINES



CEMB S.p.A.

Via Risorgimento, 9
23826 MANDELLO DEL LARIO (LC) Italy
www.cemb.com

Industrial balancing division:

phone +39 0341 706111
fax +39 0341 735678
Italy e-mail: industry.it@cemb.com
Export e-mail: industry@cemb.com

CEMB HOFMANN UK

www.cembhofmann.co.uk

CEMB SHANGHAI OFFICE

www.cemb.com.cn

**HOFMANN Maschinen-
und Anlagenbau GmbH**

Altrheinstrasse, 11
D-67550 WORMS - GERMANY

HOFMANN 

tel. (+49) 06242 904 0
fax (+49) 06242 904 286
www.hofmannmaschinen.com
e-mail: info@hofmannmaschinen.com